

## Refrigerator - 50's Style - FAB10RNE

Refrigerator, 50's Style , 50's Style , One Door, Free Standing, Hinge position: Right, Black, Static, A+

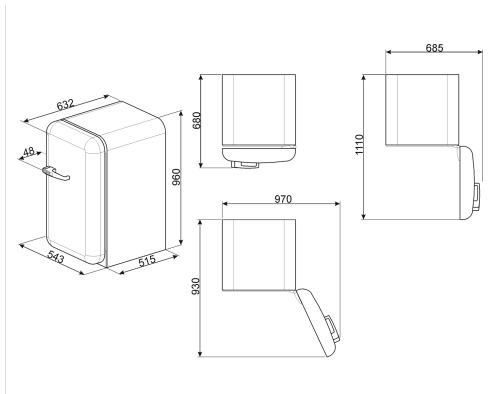

### OPTIONAL



## TYPE

Cooling type: Static • Product Family: Refrigerator • Defrost: Automatic for refrigerator, manual for freezer • Installation: Free Standing • Category: One Door • Hinge position: Right • Hinge type: Standard

## AESTHETICS

Design: Rounded • Side colour: Black • Serie: 50's Style • Side material: Steel • Finishing: Glossy • Aesthetics: 50's Style • Aesthetics: 50's Style • Door colour: Black • Handle type: Fixed • Handle: External • Colour: Black • Material: Heat-moulded • Handle colour: Chrome

## REFRIGERATOR COMPARTMENT FEATURES

Crisper Cover: Yes • Type of crisper/vegetable drawers cover: Standard • Type of adjustable shelves: Glass • No. of adjustable shelves: 2 • Number of fruit and vegetables drawers: 1 • Type of internal light (fridge): LED • Internal light in fridge: Yes • Type of crisper/vegetable drawers cover: Glass

## REFRIGERATOR INNER DOOR

Number of adjustable door shelves: 1 • No. of bottle shelves: 1 • No. of door shelves with transparent cover: 1

## OTHER REFRIGERATOR FEATURES

Accessories: Bottle holder, Egg tray

## FREEZER COMPARTMENT FEATURES

Internal freezer compartment: Yes

## OTHER TECHNICAL FEATURES

Type of temperature control: Electro-mechanical • Antibacterial Gasket: Yes • No. of compressors: 1 • Type of compressor: Standard • Freezer compartment accessories: Ice cube tray

## PERFORMANCE / ENERGY LABEL

Noise level: 37 dB(A) re 1pW • Fresh Food compartment - Storage Volume: 101 l • Category of the household refrigerating appliance model: 7 - Refrigerator-freezer • Gross volume frozen food compartment: 13 l • Temperature Rise Time: 10 h • Total storage volume: 114 l • Annual energy consumption: 169 kWh/a • Climatic class: SN • Fresh Food compartment - Gross Volume: 107 l • All Frozen Food compartments - Storage volume: 13 l • Energy efficiency class: A+ • 4 Star compartment - Star rating: 4 • Total gross volume: 120 l • Freezing capacity: 2 Kg/24h

## ELECTRICAL CONNECTION

Voltage (V): 220-240 V • Plug: (F;E) Schuko • Plug: Schuko • Frequency (Hz): 50 Hz • Power supply cable length: 170 cm • Current: 0.22 A

## OPTIONAL ACCESSORIES

## LOGISTIC INFORMATION

Product depth with handle: 680 mm • Product width with maximum doors opening: 970 mm • Height max: 960 mm • Product depth with doors open at 90°: 1110 mm